

## LATE MODEL - 2018

### CHASSIS

		LEFT SIDE WEIGHT
Tubular Frame cars w/coilovers		
Built Motor Cars	2750	58%
604 Crate Motor	2650	58%
602 Crate Motor	2550	59%

### ENGINE RULE

Cast iron blocks only.  
Engine compression cubic inch not limited  
One Carburetor (any size)

### CLUTCH AND TRANSMISSION

Must have forward and reverse gears

### WHEELS, TIRES

10" Steel wheels only (any offset)  
Track Tires- Tires must be purchased from Sayre Speedway dealer and must have Sayre seal stamped on tire

### SHOCKS AND SPRINGS

Any Shock and Springs  
Bump Stops OK

### FUEL CELL

Fuel cell mandatory. 8" minimum ground clearance. Must have 2 straps across top of cell to protect cell.

### BODY

Any late model bodies or outlaw type bodies no wider than 82".

### SPOILER

6" Spoiler

If you have questions call Bary Martin (205) 674-0367  
For Race Car Numbers, call Sandra Parker (205) 798-2171

## GENERAL RULES

**\*THE INTENT AND INTERPRETATION OF THE RULES WILL BE THE DECISION OF OFFICIALS IN CHARGE. IT IS STRONGLY RECOMMENDED THAT ANY COMPETITOR THAT HAS ANY QUESTIONS OR DOUBT ABOUT THE INTERPRETATION OR INTENT OF THE RULES CHECK WITH SPEEDWAY OFFICIALS. ALL DECISIONS OF THE OFFICIAL IN CHARGE SHALL BE FINAL.**  
Unless otherwise stated in a particular division, **these general rules apply to all divisions.**

### SAFETY

**NOTE: The following safety rules set forth by the SPEEDWAY do not guarantee prevention of personal injury, but are a guideline to building a safer racing vehicle.**

- A. Fuel cells are required. The maximum capacity allowed is 22 gallons. Fuel cell must have a working check valve and foam.
- B. Fuel cell must be mounted equal distance between rear frame rails and at least 8" above ground.
- C. Fuel cell vent and overflow may not exceed 1" in diameter. Overflow must exit at rear of car.
- D. Fuel cell must have four (4) 1/8" x 1" straps under cell and at least two (2) on top of cell bolted to fuel cell frame.
- E. Fuel cell must be protected at rear by 1-1/2" roll bar tubing extending below rear of frame 1/2" beyond bottom of cell and the width of the cell, with one (1) center brace.
- F. Fuel line must be run in metal tubing or metal conduit from cell to pump. No electric fuel pumps permitted.
- G. Cars must have fire extinguisher on-board in working order with gauge. The fire extinguisher must be in driver's reach.
- H. Drive Shaft and Bolt on Lead or Ballast must be painted white.
- I. Window Net required. Must release from top and mount on roll cage at bottom.
- J. Steering Wheel must be padded at center. Release hub recommended.
- K. All Roll Bars in driver's reach must be padded.
- L. No open holes in floor pan or firewalls permitted.
- M. **Five (5) Point Harness System with 3" lap belt and shoulder harness required.**
  1. Both ends must be fastened to roll bar cage of car with aircraft quality bolts, no less than 3/8" in diameter.
  2. A steel plate may be welded to roll bar cage on right side of driver so that the belt can be brought down in such a manner that it will keep the driver from sliding from side to side under the belt.
  3. The belt must come from behind the driver over roll bar.
- N. At least two (2) return springs required on throttle.
- O. Switches must be within driver's reach with belts on.
- P. Helmets are required and should meet Federal Motor Vehicle

Safety Standards.

**Q. All drivers are required to wear approved flame retardant suits and gloves during all practice, qualifying and race conditions. (NO Coveralls)**

**R.** Radiator overflow must be run up to windshield so driver or official can see water in case car runs hot.

**S.** Absolutely **NO ANTIFREEZE** in coolant system.

#### **ROLL CAGE**

1. Steel Roll bars must be 1 1/2" outside diameter minimum.
2. Four (4) bars are required on driver's side extending from main cage to door, three (3) bars on right side. All seams and joints must be welded solid.
3. Roll Cage must be approved by SPEEDWAY officials before entering race track.

#### **SEATS**

1. Bucket seats are mandatory and must be approved. Seats may be fiberglass or aluminum, bolted to seat frame attached to roll cage.
2. Seat must be high back with padded head rest.
3. Location of seat cannot extend past rear of door.

#### **APPEARANCE**

1. All cars must be neatly painted and maintained.
2. Numbers must be at least 24" on both right and left side of car. No Silver or Gold numbers. **TWO NUMBERS ONLY. NO LETTERS**
3. **NO duplicate numbers.** Numbers have to be assigned through the track. Duplicates will be reassigned at track discretion.  
For number Call: Sandra Parker 798-2171 or 999-3510.

#### **PROTESTS**

- A.** Only drivers can appoint someone to inspect car or protest. Protesting driver must compete in feature race. No protesting anyone finishing behind you. All protest must receive approval of Chief Pit Steward. Spite protest or protest done in an unsportsmanlike manner will not be accepted. Protest must be made within 10 minutes of feature. You have 45 minutes to be ready to be teched.
- B.** Visual protest (requiring no measurements whatsoever) must be presented to Chief Pit Steward in writing BEFORE THE DRIVERS MEETING starts. \$30.00 non refundable charge. **NO VISUAL PROTEST CAN BE MADE AFTER THE RACE IS OVER.**
- C.** All other protest or claims must be presented to Chief Pit Steward in writing within 10 minutes of finish of feature race accompanied by \$150.00 per protest; \$25.00 is given to the person designated to make measurements; and \$125.00 to the driver who wins the protest.
- D.** Driver of cars found illegal forfeit points, money earned and will start on rear the next race they attend.

#### **ENFORCEMENT**

- A.** The fact that an infraction is not noted does not make it legal.

#### **SAFETY**

*No restrictions will be made on safety. Anything may be added to car to make it safer.*

Racing seat belts required.

Full cage or plate and post required.

1/4" plate on drivers door. Must overlap the front fender at least 6" and the rear door or quarter panel at least 6". Must have (2) 4" post with plates on each end bolted to roof and floor pan behind driver seat.

Fuel cell or 6 (six) gallon gas tank recommended.

Fire extinguisher must be in drivers reach.

Bumpers must be chained with bolts or welded to prevent them from coming off.

**NO** glass except front windshield

#### **APPEARANCE**

All cars must have neat appearance. Header panels will have to be replaced within 2 weeks. Numbers must be readable to be scored. Non-reflective and contrasting (example light color numbers on dark car, dark numbers on light car). **NO THREE DIGIT NUMBERS. NO LETTERS. NO EXCEPTIONS.**

**NO two way radios**

## 2018 HOGGS

**THE INTENT AND INTERPRETATION OF THE RULES WILL BE THE DECISION OF OFFICIALS IN CHARGE. IT IS STRONGLY RECOMMENDED THAT ANY COMPETITOR THAT HAS ANY QUESTIONS OR DOUBT ABOUT THE INTERPRETATION OR INTENT OF THE RULES CHECK WITH SPEEDWAY OFFICIALS. ALL DECISIONS OF THE OFFICIAL IN CHARGE SHALL BE FINAL.**

**DRIVERS** - Drivers that can run this division will be at track discretion

**CARS** - 104" Wheel Base Minimum.

**NO low profile (such as Camaro, Firebird, Mustang).** Monte Carlo, Cutlass, Regals can run 350 Chevy engines or what came in car. Must pull no less than 17 inches of vacuum at 1000 RPM. May run V-6 Front Wheel Drive car with book size tires and rims and can be fuel injected. V6 cars may run straight shift transmission. NO V-8 Fuel injected cars allowed. ALL GM cars can run 350 chevy engines

### **WHEELS AND TIRES**

Radial Tires Only. **NO** Recaps. No tires larger than 235-70/15 unless came on car. Same size tires all the way around. May run racing wheels. 3 1/2" offset all 4 wheels. 7" wheels only.

**SOAK RULE** No Soaking or altering of tire in any manner allowed.

Drivers soaking or altering tires will forfeit all purse and points for event and all points for year. Driver must also pay a \$1,000 fine prior to racing again. Any illegal tire (decision by track official) will be confiscated.

### **ENGINE AND DRIVE TRAIN**

Stock block, crank, rods, heads. No porting or polishing. May be bored. Hydraulic cams only. Exhaust must be run past the driver door post unless you run header up and out the hood only. (**NO** headers under car) Car must have air cleaner. GM cars must run #7448 stock Holley 350 2 barrel carburetor. Fords and Dodges have to run Holley 500 carburetor #4412. No altering metering blocks. Must remove choke flaps

### **BODY FRAME AND SUSPENSION**

1. Body stock in every way - 4 door or 2 door. Side glass must be removed. Doors must be welded or strapped shut. May replace windshield with lexan.
2. No frames lower than 7" (seven inches).
3. Suspension must be stock type. **NO** independent rear suspension V-8 Cars
- 4, NO locked rear ends or limited slips

- B. Chief Pit Steward may add weight for infractions that create an advantage.
- C. The Chief Pit Steward has the final word on any rule or protest.
- D. All problems will be handled in a calm and sportsmanlike manner. Anyone not conducting themselves in a sportsmanlike manner may have their license revoked for an indefinite period of time.
- E. Loose lead found on any car after race will automatically disqualify car. **(NO Excuses)**
- F. Can be black flagged for dragging pieces. Will need to be checked for safety by pit official.
- G. If you spin someone out, **BOTH** cars will be sent to rear.

### **CONDUCT IN PIT AREA**

- A. Drivers and/or car owners are responsible for their entire pit crew.
- B. **ABSOLUTELY NO DRINKING BY ANYONE WILL BE ALLOWED IN THE PIT AREA.**
- C. Any pit crew member or anyone else in the pit area who violates the above stated rule will be in contempt and be fined \$50.00. In addition, the driver will lose all winnings and points for the event, and will be suspended from the next racing event.
- D. Drivers and crew members will conduct themselves in a calm and sportsmanlike manner at all times. Any one throwing anything will be Fined & Barred. Minimum Fine \$100.
- E. Any crew member or fan in the pit area who uses loud and abusive language towards a pit crew member or track official, or any individual who is guilty of starting or **engaging in a fight will be fined a minimum of \$100.00.** In addition, the driver will lose all winnings and points for the event, and could be suspended from the next 2 (two) racing events. According to severity, suspension can be indefinite. Anyone hitting a track official will be fined \$200 and suspended. Family or fans coming out of stands will automatically cause driver to lose points and money for that night.

### **FUEL**

The only approved fuel for operation of any racing vehicle on the SPEEDWAY is racing gasoline. ALCOHOL OR NITROUS IS STRICTLY PROHIBITED. Violations subject to a fine of \$200.00.

**NOTE:** The SPEEDWAY reserves the right to modify/change rules during the season as deemed necessary for safety, fair competition, or any other reason that track officials feel may be appropriate.

**TRACK HAS THE RIGHT TO BAR ANYONE WE FEEL IS BEING DETRIMENTAL TOWARDS THE TRACK OR DRIVERS THROUGH SOCIAL MEDIA OR ANY OTHER MEANS.**

## GENERAL RULES Continued

### ATTENTION ALL DRIVERS

#### **NO PROFANITY ON CARS. NO SUGGESTIVE ART WORK ON CARS.**

Drivers **MUST** purchase a yearly membership pit license before you race.

This year we will award points for the top five in all divisions.

Points will be awarded in each division you race in. Therefore you **MUST PURCHASE** a membership pit license for each division you race in.

**YOU CANNOT** race in 2 (two) divisions in the same night except for the Renegade and Hot Shots. Anyone may run these divisions as long as you have a **MEMBERSHIP** for **EACH CLASS** you race in.

**YOU CANNOT** race in Buzz or Street once you move up from those divisions.

- May cut holes in hood for air cleaners. Must check with official before running. Stock, firewall and floor pan (front and rear).
2. Stock size windshield. Side windows no more than 12 inches back on each side.
  3. Safe steering shaft.
  4. Dash may be made with steel or aluminum. Must reach from one side to the other side.
  5. Car must be safe in all ways possible. (See General Rules)
  6. Car must have neat appearance
  7. Spoiler - 5" spoiler

### **WHEEL, TIRES, BRAKES AND SUSPENSION**

1. Steel wheels. 8"
2. **TIRE RULE:** Track tires

Tires must be purchased from Sayre Speedway dealer and must have Sayre seal stamped on tire

**SOAK RULE NO** Soaking or altering of tire in any manner allowed. Drivers soaking or altering tires will forfeit all purse and points for event and all points for year. Driver must also pay a \$1,000 fine prior to racing again. Any illegal tire (decision by track official) will be confiscated.

3. Stock brakes. Can run adjustable brake pedals
4. Stock suspension required in stock position - may be reinforced. A-frames can be shortened or lengthened to set front-end. May run Jack Bolts in rear.
5. Weight may be added for minor infractions
6. Heim joints legal on suspension

### **CLAIM & PROTEST**

All protest will be handled in an orderly manner. Refer to General Rules. You have 10 minutes to protest after the race.

NO Two way radios

THE **WINNER** FROM THE **LAST RACE** WILL **START** NO BETTER THAN 9TH PLACE

**Buzz cars with fuel injection may move up to mini modified if needed. Weight starts at 2300 lbs with mini modified tires**

## 2018 MINI MODIFIED

**\*THE INTENT AND INTERPRETATION OF THE RULES WILL BE THE DECISION OF OFFICIALS IN CHARGE. IT IS STRONGLY RECOMMENDED THAT ANY COMPETITOR THAT HAS ANY QUESTIONS OR DOUBT ABOUT THE INTERPRETATION OR INTENT OF THE RULES CHECK WITH SPEEDWAY OFFICIALS. ALL DECISIONS OF THE OFFICIAL IN CHARGE SHALL BE FINAL.**

### CARS LEGAL FOR DIVISION

Any 4 cylinder, 2 or 4 door (4 passenger) sedan, or station wagon foreign or domestic - between 90" and 105" wheel base.

**FUEL CELL** - Fuel cell **REQUIRED**. Must be mounted securely with 10" (ten inch) ground clearance. **ALL CARS** will have a fire wall between driver and fuel cell.

### ENGINE AND DRIVE TRAIN

1. Engine must be factory stock for make and model of car in stock position.
2. 2000 lb. minimum after race. Mustang with stock appearing body must weigh 2150 lbs. Mini Modified type cars with coil over type shocks and fiber glass bodies will have to weigh 2250 lb.
4. Engine can be balanced.
5. May run after market rods
6. No lightening or knife edging cranks (can be balanced). Stock stroke.
7. Anything can be done to the head. May be ported and polished and run any valve size. Fords may run aluminum heads.
8. Any aluminum intake with maximum of 2" from intake to carburetor.
9. May run roller cam and rockers on Fords
10. Exhaust headers optional.
11. May run single or double disc type clutches such as 10,000 RPM or Goldstar, or Tilton with Aluminum Flywheel.
12. Stock transmission and rear ends. (Locked rear ends optional)
13. Carburetor stock 350 CFM (7448) Holley Carburetor. Must fit gauges. May remove choke plate. **No** cold air boxes.
14. Battery can be located behind driver but must be covered if run there. Must be self starting.

### BODY AND APPEARANCE

1. Bodies may be fiberglass or Aluminum

## 2018 OPEN WHEEL MODIFIED RULES

THE INTENT AND INTERPRETATION OF THE RULES WILL BE THE DECISION OF OFFICIALS IN CHARGE. IT IS STRONGLY RECOMMENDED THAT ANY COMPETITOR THAT HAS ANY QUESTIONS OR DOUBT ABOUT THE INTERPRETATION OR INTENT OF THE RULES CHECK WITH SPEEDWAY OFFICIALS. ALL DECISIONS OF THE OFFICIAL IN CHARGE SHALL BE FINAL.

### GENERAL

1. American made frames 105" wheel base minimum.
2. Cars must weigh 2550, 1 pound per lap burn off
3. Rear of engine must be mounted 72 inches forward from center line of rear axle. Engine offset within 2" of center of crossmember.

### ENGINE

1. Steel heads and block only, Aluminum Heads (50 lb. Penalty)
2. One Carburetor, 2 or 4 barrel (may run gas or alcohol)
3. Transmission must have at least two forward and one reverse, plus a neutral position with engine running. Steel drive shaft only.
4. Shocks - One per wheel. No bump stops on shocks. No canister shock
5. Stock type ball joints.

### WHEELS & TIRES

1. Steel wheels - max width 8"
2. TIRES - Track tires

Tires must be purchased from Sayre Speedway dealer and must have Sayre seal stamped on tire.

3. **SOAK RULE NO** Soaking or altering of tires in any manner allowed. Drivers soaking or altering tires will forfeit all purse and points for event and all points for year. Driver must also pay a \$1,000 fine prior to racing again. Any illegal tire (decision by track official) will be confiscated.



## OPEN WHEEL MODIFIED BODY DIMENSIONS FOR 2018

- A. 20 "max 16" min. (ground to center of bumpers, front and rear)
- B. 6.5 min. (center to center)
- C. 52" max. 42" min.
- D. Hood 4" max. drop (sides). sealed off from driver's compartment and max. 3" rake.
- E. 42" max.
- F. 6" max.
- G. 4" min.
- H. 19" max., must be same on both sides.
- I. 112" max. 108" min.
- J. 27" max 22" min.
- K. 72" max. or not past back of block, right side. Left side may extend forward to cover foot box.
- L. 18" max. 12" min. opening, both sides.
- M. With level, must have between 1/2" and 2" clearance at rear of roof, 1/2" to 5" at front.
- N. 120" max. 106" min.
- O. 48" max. 34" min.
- P. Spoiler 8"
- Q. Interior slope is 6" max. front to rear and flat across. If flat at front half of interior you have used up 50 % of your 6" so from behind driver to rear you may only have 3". Top of interior must be flush with top of door and quarter panels. An optional escape hatch from driver to passenger door to provide 12" opening allowed.
- R. 38" max 28" min.
- S. Max. no wider than front frame horns. Min. 24"
- T. 66" max. 24" min. no narrower than radiator.
- U. 52" max 44" min.
- V. 56" max. 41" min.
- W. Tires must be widest part of car.
- X. 66" max. 53" min.
- Y. All rear bumpers must be constructed of square or round tubing, no wider than five inches outside of rear frame rails and similar to drawing. If rear bumper is wider than five inches outside rear frame rails, it must be constructed in a loop design.

## BODY AND APPEARANCE

- 1. Late Model type bodies allowed - 50 lb penalty
- 2. Outlaw Late Model bodies allowed - 50 lb. penalty
- 3. May run stock steel Monte Carlo type roof with no penalty
- 4. Body no lower than 5" from ground
- 5. Car must be safe in all ways possible. (See General Rules)

## WHEELS, BRAKES AND TIRES

- 1. Steel wheels - 8".
  - 2. Disc Brakes may be run.
  - 3. **TIRES:** Track Tires. Tires must be purchased from Sayre Speedway Dealer and must have Sayre seal stamped on tire.
- SOAK RULE NO** Soaking or altering of tire in any manner allowed. Drivers soaking or altering tires will forfeit all purse and points for event and all points for year. Driver must also pay a \$1,000 fine prior to racing again. Any illegal tire (decision by track official) will be confiscated.

Starting weight - 2950 lbs

### **PENALTYS**

After Market body or Late model or Outlaw	50 lb
Motors over 360 cu. in.	50 lb.
Roller Cams	25 lb
After Market Heads	50 lb
Fire wall & Floor pan not stock	50lb

### **STOCK SNOUT CARS**

**after market body and fabricated firewall 5" springs  
9" Ford floater rear end 56% left side weight.  
FB and WB type shock only.  
weight 3200 lbs.  
outlaw body no penalty  
aftermarket head no penalty**

**PROTEST RULE** Protest must be handled as stated in General Rules.

- 1. **\$150 to see top end of motor - (that means anything that can be seen from top) bore, stroke, camshaft, head porting, no ported intakes or matching gaskets. \$50 to check for roller cam. This will be done by pulling the distributor.**

THE WINNER FROM LAST RACE WILL START NO BETTER THAN 9TH PLACE.

\* If the rules don't say you CAN you CAN'T!

## 2018 SPORTSMAN

**\*THE INTENT AND INTERPRETATION OF THE RULES WILL BE THE DECISION OF OFFICIALS IN CHARGE. IT IS STRONGLY RECOMMENDED THAT ANY COMPETITOR THAT HAS ANY QUESTIONS OR DOUBT ABOUT THE INTERPRETATION OR INTENT OF THE RULES CHECK WITH SPEEDWAY OFFICIALS. ALL DECISIONS OF THE OFFICIAL IN CHARGE SHALL BE FINAL.**

### GENERAL

1. Anything not specified in rules must be stock, in original position, from original manufacturer.
2. American made cars 108" wheel base minimum.
3. Cars must weigh minimum 2950 lbs. with driver. 57% left side weight.
4. Weight may be added for infraction of rules to make competition equal.
5. **NO** 2 way radios.

### ENGINE AND DRIVE TRAIN

1. Must be factory stock for make of car. Stock stroke. Max. .060 bore.
2. Flat top or dish pistons. Solid or hydraulic flat tappet cam only. No roller cams. May run roller rocker arms.
3. Stock cast iron heads as available from manufacturer. (**NO** porting or polishing.) Chevys may run Aluminum intake. **NO** porting or polishing intake. May run aftermarket heads and Angle plug heads with 50 lb penalty. Headers may be run. Ford & Chrysler may run aluminum intake.
4. Carburetors must be 500 cfm #4412. 1-11/16 throttle bore. Max. 1" adaptor.
5. Battery can be located in drivers compartment if covered.
6. **May run 7 1/4 disc type clutch**
7. **9" Ford Floater rear end may be run**
8. **Must be self-starting. NO electric fuel pumps**
9. **Headers may be run**

### SUSPENSION

1. Front spindle/axle/ball joint assemblies may be reinforced, or heavier duty unit from another passenger car installed. **NO** aftermarket spindles
2. Must have stock frame. Frame may be reinforced. **NO** notching or alteration to frame. Suspension type and location must remain stock.
3. **May run** wedge bolts. Shocks may be relocated on front and rear.
4. Uni-body frame sections may be connected as part of roll cage construction. A-frames must be stock, may run tubular upper A Frames. Stock Lower A Frame.
5. **SHOCKS No adjustable or Shrader Valve Shocks allowed. Steel shocks only**
6. **NO** frame lower than 5" from the ground.

Shaded area reserved for sponsor decals. **MUST DISPLAY ALL DECALS TO BE ELIGIBLE FOR ANY CONTINGENCY AWARDS OR POINT FUNDS.**

(P) 8" Spoiler

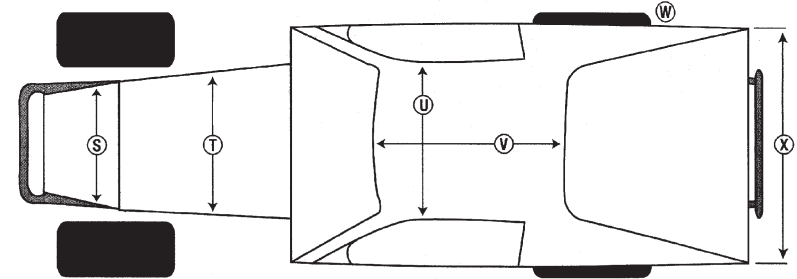
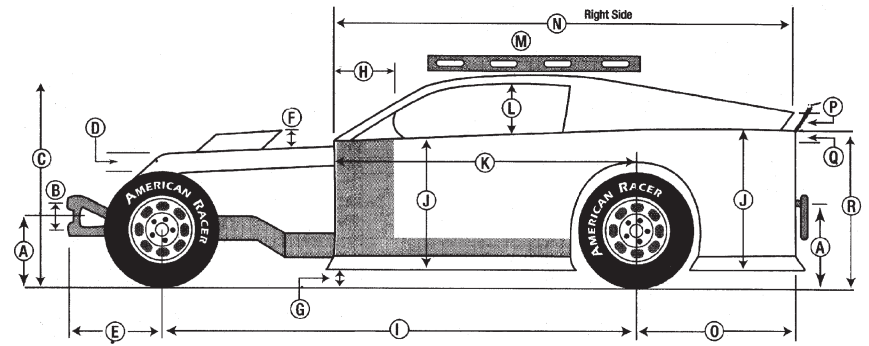

Sail Panel



Sail Panels

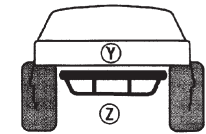

Rear Bumper

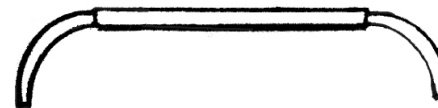

## 2018 BUZZ RULES

### READ ALL GENERAL RULES. THEY APPLY TO THIS DIVISION.

1. Any stock 4 cylinder sedan, or station wagon from 1984 model up. All cars front wheel drive only.
  2. All glass must be removed except windshield and it may be Lexan.
  3. Must have racing seat belts
  4. All flammable materials must be removed except dash and it needs to be stock.
  5. All doors, hood and trunk must be secured during race. (Welded, bolted or chained)
  6. All engines must be stock for make and model of vehicle with stock computer. Computer subject to change at Track discretion. Engines must remain completely stock in stock position. Battery may be relocated in safe place. No turbos or super chargers. Recommend safety disconnect on battery cable.
  7. No altering of frame or suspension in anyway. May add camber to right front tire. No more than 3 degrees of camber.
  8. **WHEELS AND TIRES:**
    1. All 4 wheels must be same size 14" or 15", 65 series
    2. All wheels must be stock except right front may be 7" wide racing wheel. All other wheels must be no wider than 6"
- SOAK RULE.** NO soaking or altering of tire in any manner allowed. Drivers soaking or altering tires will forfeit all purse and points for event and all points for year. Driver must also pay a \$1,000 fine prior to racing again. Any illegal tire (decision by track official) will be confiscated.
9. Vehicles must be painted neatly with contrasting numbers on the doors and on the roof. Numbers must be at least 20" tall and **non reflective.** **NO LETTERS**
  10. Starting positions will be determined by drawing numbers.
  11. Car must have 3/16 steel plate over drivers door and overlap at least 4" on fender and quarter panel or may have roll cage. May hull driver side door if you have cage.
  12. If you do not have a roll cage, you must have 2 posts behind seat with plates on top and bottom bolted to roof and floor pan with a bar between them at least 1-1/2" tubing round or square like an H.
  13. May take mufflers off and use straight pipe.
  14. Winner starts on the rear of the next race.
  15. If you win 2 championships you have to move up a class to Renegade, Street Stock, etc.
  16. Weight may be added to make competition fair.  
NO Two way radios

Contact Frank Martin for plates, post or roll cages 674-0924/674-0367.

Shaded area reserved for sponsor decals. **MUST DISPLAY ALL DECALS TO BE ELIGIBLE FOR ANY CONTINGENCY AWARDS OR POINT FUNDS.**

(P) 5" Spoiler

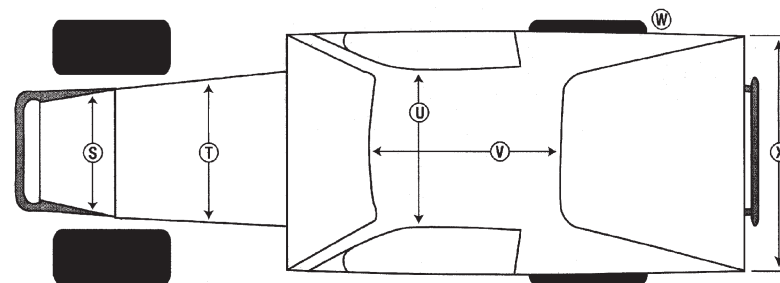
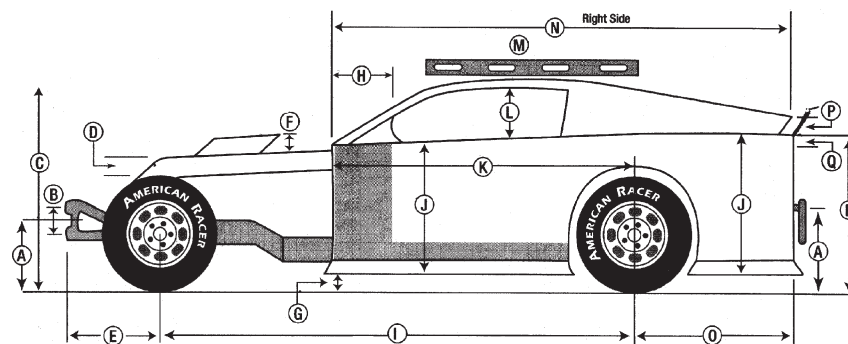

Sail Panel



Sail Panels

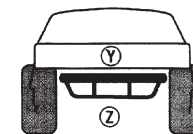

Rear Bumper

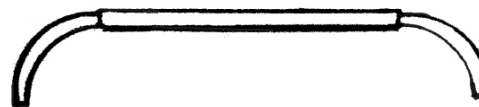



## LIMITED MODIFIED BODY DIMENSIONS FOR 2018

- A. 20" max 16" min. (ground to center of bumpers, front and rear)
- B. 6.5 min. (center to center)
- C. 52" max. 42" min.
- D. Hood 4" max. drop (sides). sealed off from driver's compartment and max. 3" rake.
- E. 42" max.
- F. 6" max.
- G. 4" min.
- H. 19" max., must be same on both sides.
- I. 112" max. 105" min.
- J. 27" max 22" min.
- K. 72" max. or not past back of block, right side. Left side may extend forward to cover foot box.
- L. 18" max. 12" min. opening, both sides.
- M. With level, must have between 1/2" and 2" clearance at rear of roof, 1/2" to 5" at front.
- N. 120" max. 106" min.
- O. 48" max. 34" min.
- P. 5" Spoiler
- Q. Interior slope is 6" max. front to rear and flat across. If flat at front half of interior you have used up 50 % of your 6" so from behind driver to rear you may only have 3". Top of interior must be flush with top of door and quarter panels. An optional escape hatch from driver to passenger door to provide 12" opening allowed.
- R. 38" max 28" min.
- S. Max. no wider than front frame horns. Min. 24"
- T. 66" max. 24" min. no narrower than radiator.
- U. 52" max 44" min.
- V. 56" max. 41" min.
- W. Tires must be widest part of car.
- X. 66" max. 53" min.
- Y. All rear bumpers must be constructed of square or round tubing, no wider than five inches outside of rear frame rails and similar to drawing. If rear bumper is wider than five inches outside rear frame rails, it must be constructed in a loop designlike drawing

## 2018 STREET STOCK

THE INTENT AND INTERPRETATION OF THE RULES WILL BE THE DECISION OF OFFICIALS IN CHARGE. IT IS STRONGLY RECOMMENDED THAT ANY COMPETITOR THAT HAS ANY QUESTIONS OR DOUBT ABOUT THE INTERPRETATION OR INTENT OF THE RULES CHECK WITH SPEEDWAY OFFICIALS. ALL DECISIONS OF THE OFFICIAL IN CHARGE SHALL BE FINAL.

1. Anything not specified in Rules must be stock, in original position, from original manufacturer.
2. American made cars from 106" to 114" wheel base. **NO** Camaros or Mustangs. May run T-Bird
3. Cars must weigh minimum of 3100 lbs. with driver after race. 56% left side weight max. Weight may be added for minor infractions.
4. 360 cubic inch - NO 400 small blocks.
5. 602 Crate Engine will be allowed. Must run by GM spec.

### ENGINE & DRIVE TRAIN

1. No engine larger than 350 CI .060 over OEM blocks only. Must have casting numbers on block.
2. CRANKSHAFT: OEM crankshafts only with casting numbers on crank. May be balanced. **NO** stroked cranks. May run racing oil pans. **MUST HAVE 1" INSPECTION PLUG** inside of pan in line with casting numbers on crankshaft.
3. RODS Must be stock appearing such as Eagle (SIR) or the Scat Rods
4. PISTONS: Flat-top pistons only (No Dome pistons)
5. CAM SHAFT: GM products: Max 455 advertised (300 lobe lift)  
Ford products: Max. 480 advertised (300 lobe lift)  
Chrysler products: Max. 480 advertised (300 lobe lift)  
Hydraulic camshafts only. Cam lift determined by measuring lift at the lifter, then multiplying by rocker arm ratio. No solid, or roller cams. Stamped steel rocker arms. **3/8 studs only in all heads**
6. INTAKE: Stock aluminum intake. **NO** hi rise intakes.  
Chevys can run intake #2101  
Fords can run 2750 windsor 2181
7. **HEADS: NO Vortec, 305, double hump or Angle plug, or Center Bolt valve cover heads allowed. Casting # will have to be on Heads. Some casting # for 350 Chevy are: (39863336), (333882), (462624), (3932441), (3973487), (3998993), (3973493), 1.500, 1.940 valves on Chevys. NO closed chamber heads on Fords, must run open chamber heads. Stock size on all others. Stock size valve springs for make. No grinding of heads whatsoever. May run stock aluminium intake. NO hi-rise intakes. Headers may be run. May cut center of intake out for 2 barrel. Ford casting Numbers to be announced.**

8. Carburetor must be 7448, 350 cfm Holley 2 barrel with choke removed. **NO** spacers, 1" adapter only. **NO** cold air boxes. **NO** tongue type air cleaners.
9. Stock automatic transmission may run remote cooler, stock converter. May run power glides, Straight shift transmission with 100 lbs penalty.  
No Muncie transmissions or aluminum transmissions in Chevys. Fords and Chrys may run aluminum transmissions. Stock type clutch and pressure plate, L-88 fly wheel on Chevys. **NO ALUMINUM.** Must have Blow Proof Bell Housing, cut out on bottom for inspection. No stock Bell Housing. Straight Shift cars need to be inspected before they race. May run hydraulic throwout bearing and pedal.
10. Stock rear end for make, any gear (may change ratio). Mini spools or welded (**NO** lockers) or limited slips.
- 11.. Battery can be in drivers compartment if covered.
12. Stock ignition must be self starting. **NO** electric fuel pumps.
13. Engine must be in stock position, **POSITIVELY NO** engine set back

#### **SUSPENSION**

1. Stock spindles for year and make of car
2. Stock frame for the year - model car. Frame may be reinforced. **NO** altering frame. All suspension must remain stock. **NO** altering of A-Frames
3. Springs may be replaced but must remain in stock location
4. Wedge Bolts allowed in rear and hidden screw adjusters in front.
5. Shock must remain stock. **NO** racing shock such as AFKO, PRO, Bilstein, Carrea. Number must remain on shock or it is illegal. One (1) shock per wheel in stock location.
6. Frame no lower than 6" from ground.
7. **NO** offset cages.

#### **BODY AND APPEARANCE**

1. Windshield may be replaced with Lexan
2. May cut for wheel clearance. Full stock body, door jams, firewall. Floor pan must remain stock. Trunk lid and roof may NOT be hulled. Hoods may be hulled. May cut hole in hood for air cleaner. Dash may be made of steel or aluminum and **MUST** reach from one side to other. Doors may be made out of aluminum
3. Body must be stock and in stock position on frame. **NO** lowering, narrowing or chopping.
4. Car must have neat appearance. **AFTER MARKET NOSE AND TAIL PIECES MAY BE RUN.**
5. Car must be safe in all ways possible (See General Rules). Cars will not run with header panels missing over 1 week.
6. Core support will remain stock.
7. May have 4" posts and 3/16 plate on door.
8. Roll cages recommended in driver compartment.

6. **TRANSMISSION:** 3 or 4 speed only, no racing transmission (like Tex, Jerico, Bert, Falcon, Brinnn)
7. **FUEL CELL:** Must be at least 8" from ground and have at least 2 1" straps around it.
8. **CLUTCH:** 7 1/4", 2 or 3 disc type clutches allowed only.

#### **WHEELS, BRAKES AND TIRES**

1. 8" Steel Wheels only
2. Tires: Track Tires

Tires must be purchased from Sayre Speedway dealer and must have Sayre seal stamped on tire.

**SOAK RULE NO** Soaking or altering of tire in any manner allowed. Drivers soaking or altering tires will forfeit all purse and points for event and all points for year. Driver must also pay a \$1,000 fine prior to racing again. Any illegal tire (decision by track official) will be confiscated.

**NO two way radios**

#### **PROTEST**

All protest must be handled in an orderly manner. Top end protest \$200.00. This checks for flat-top pistons, bore, stroke, ported heads, size of valves and cam lift. To pull intake is \$100.00. This checks cam lift and ported and polished heads. Drivers that can run this division will be at track discretion.

#### **WEIGHT RULE**

1. 2500 lbs after race with driver.
- 2.. Weight may be added for minor infractions

**IF THESE RULES DO NOT STATE YOU CAN DO IT, YOU CANNOT.**

This division is based on keeping this class inexpensive like the Street Stock. Remember - Keep it cheap.

## 2018 LIMITED MODIFIED RULES

### ENGINE

#### ENGINES:

1. No engine larger than 350 cu in. .060 over OEM Blocks only. Must have casting #'s on block. Engine set back 72" from back of block to center of rear end housing.
2. **CRANKSHAFT:** Stock stroke, Cast Eagle or Scat cranks ok (No stroker cranks)
3. **RODS:** Must be stock appearing rods
4. **PISTONS:** Flat-top pistons only (no Dome pistons) .060 max. bore.
5. **HEADS:** Cast iron heads only (No vortex, 305, double hump or closed chamber heads. Casting # (39863336), (333882), (462624), (3932441), (3973487), (3998993), (3973493, 1.940 intake valves, 1.500 exhaust valves on all heads Chevy, Ford, Dodge. No grinding or porting on heads. **NO** matching intake.
6. **INTAKE** Typhoon or Edelbrock 7101 Performer RPM. **NO** matching, grinding or porting on intake.
7. **ROCKER ARMS:** Roller Rocker arm allowed. 1.5 on Chevy; 1.6 on Ford. Numbers must be on Rocker Arms.
8. **CAMSHAFT:** Hydraulic cam only. (**NO** roller Cams) 490 lift max. with .005 tolerance.
9. **CARBURETOR:** 350 2 barrel stock, choke may be removed. Must check with gauges at any time before or after race. 1" adaptor only.
10. **DISTRIBUTOR:** HEI stock type or MSD OK to run.
11. **HEADERS** may be run.

### SUSPENSION and DRIVE TRAIN

1. Stock type ball joints.
2. **SHOCKS:** Steel shocks only. **Fix Bearing type SHOCKS** or (WB Series) or (FB Series) type only.  
**Buy rule on shocks.** May buy front shocks \$160 or rear shocks \$160. (Front and rear \$320)
3. **DRIVE SHAFT:** Steel only
4. **FRAME HEIGHT:** 4" at lowest point (Except cross members)
5. **REAR END:** 9" Ford allowed, Floaters allowed. Mini-spool or full spool only. (No quick changes) **NO** Lockers

Ok to add bars under hood or trunk.

9. Numbers must be at least 20" tall and non reflective. Must contact Sandra Parker (798-2171) for car number available in your class.  
**NO duplicate numbers. NO** Letters

### WHEELS, BRAKES & TIRES

1. Steel wheels only 7" or 8", 3" offset wheels only. Same offset on all 4 wheels.
2. Disc brake on front and drum on rear. **NO** Neal pedals for brakes. One master cylinder.
3. **TIRES:** Track tires

Tires must be purchased from Sayre Speedway dealer and must have Sayre seal stamped on tire

**SOAK RULE NO** Soaking or altering of tire in any manner allowed. Drivers soaking or altering tires will forfeit all purse and points for event and all points for year. Driver must also pay a \$1,000 fine prior to racing again. Any illegal tire (decision by track official) will be confiscated.

### PROTEST

All protest must be handled in orderly manner. Refer to General Rules. \$125 to see top end, \$125 to see bottom end. \$50 to check cam lift, \$50 to pull intake, \$25 to check wheels. \$50 to pull inspection plug

NO Two way radios

For rule information, call Frank Martin 674-0924/674-0367. He has material for posts and parts for all your racing needs.

## HOT SHOTS 2018

American made 2 or 4 door sedan or station wagon. V-6 front wheel drive cars or V-6 trucks. American made Ranger, S-10, Explorer, Blazers, Dakotas, Durangos. 4-cyl cars Cavaliers, Alero, Sunfires, Avengers. CARS; Tarus, Impala, Malibus, Regals, Olds Cutlass, Monte Carlo, Grand Prix. NO SPORTS CARS

### DRIVE TRAIN AND ENGINES

1. Completely stock, NO altering of any kind
2. Horn must blow
3. Radio must work
4. Gauges must work (Factory ones). Dash must be in car stock
5. May have Quick Release Steering wheel and shaft (goes with car)
6. Racing Seat and Belts (mandatory). Fire Extinguisher also mandatory
7. NO hulling of any kind, except driver door for roll cage
8. Must have post and plates if you don't have roll cage
9. Roll cages recommended
10. Stock wheels and tires for cars, trucks and SUVs. Book size. Must have proof of stock size tires.
11. Must have owners manual in glove box of truck or car. If owners manual not available must have proof of stock size in glove box, (i.e printed off internet.)
12. Engine stock for make and model. DO NOT take anything out from under hood.
13. NO headlights or side glass in cars
14. NO adding camber of any kind
15. NO taking anything out from under the hood.

## CLAIM RULE

\$1,000.00 Claim on car or truck minus safety equipment, seat belts and cages if bolted in. If welded goes with car. The winner is only car on track that can be claimed.

This is a new class. Track has the right to modify rules as needed. This is going to be a class for fun and entertainment. ANYBODY can run this division and run another division the same night.

**AGAIN THIS CLASS IS FOR FUN**

When enough cars are built we would like to have some 100 lap races. \$1000 to win. Track may buy winners car for \$1000. Car to be auctioned off.